

FRIES







PP series

**ROUND CAN** 1100 ml

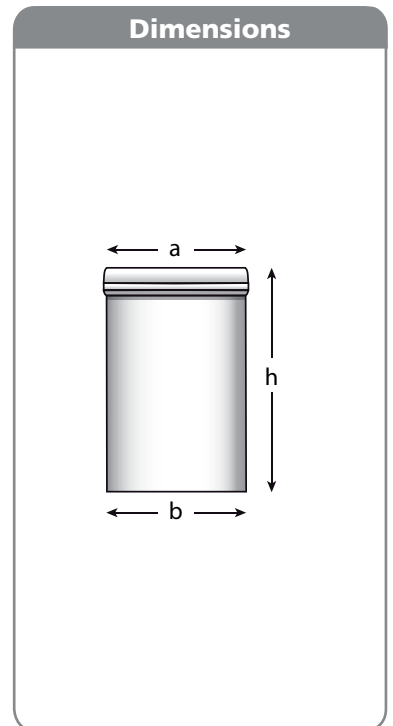
# Round can 1100 ml | PP series

Overview			
Nominal volume:	1,100 ml		
Item name:	DO1100PP		
Max. filling volume:	1,100 ml	± 5.0 %	
Dimensions (with lid):	a 109 mm	± 2.0 %	
	b 100 mm	± 2.5 %	
	h 156 mm	± 2.0 %	
Material and colour:	Bottom part:	PP, white or black	
	Lid:	PP, white or black	
	Handle:	----	
Weight:	Bottom part:	57 g	± 4.0 %
	Lid:	11 g	± 7.5 %
	Handle:	----	
	Total:	68 g	± 4.0 %
Max. printable surface:	----		
Approval: 	----		
Empty packaging dispatch on pallet (max. height 200 cm):	880 pcs. of cans per EP and 14,400 pcs. of lids per EP alternatively: 702 pcs. of cans and lids per EP		



Detailed view	Advantages
 <p>Pouring section</p>  <p>Reopening section</p>  <p>Protective ring</p>	<ul style="list-style-type: none"> <li>- Clip-on lid, can be closed easily (automation)</li> <li>- Circumferential protective ring, the efficient protective rim</li> <li>- Tamper-evident closure</li> <li>- Tight lid seat: tight<sup>1)</sup> up to 20 kP (200 mbar) of pressure difference</li> <li>- Watertight<sup>2)</sup> lid acc. to ADR 6.1.5.2.6. para. 2</li> <li>- Smooth interior surfaces for effective residue emptying</li> <li>- Approved for food contact, acc. to EC 1935/2004, EC 2023/2006 and EC 10/2011 in the currently valid version for the simulants A, B, C, D1, D2, E for colour WHITE and BLACK (other colours on request)</li> <li>- UN type tested version for solids: on request</li> </ul> <p><sup>1)</sup> The pressure difference is built up in increments of 10 kP (100 mbar), 2 min. holding time; - Higher pressure difference values result in leakages</p> <p><sup>2)</sup> Package filled with water (98%); normal conditions: a) 5 min. lying on the side b) 24 h standing "upside down" - no leakage of liquid detected</p>



**FRIES Kunststofftechnik GmbH**  
 Schützenstraße 19, 6832 Sulz, Austria  
 P +43 (0)5522 4935-202, F +43 (0)5522 4935-209  
 E [info@fries.at](mailto:info@fries.at), [www.fries-kt.com](http://www.fries-kt.com)

